

HHP Heater Hanging Mounting Bracket (HMB) Installation Instructions

Ensure heater model number corresponds with the correct model and size of mounting bracket identified on the outside of packaging.

WARNING!

Refer to heater owner's manual for mounting specifications and conditions. If the heater is installed on a structure that is to be transported, provide additional support for heater during transit. Suspended weight should not exceed 500 lbs (227 kg).

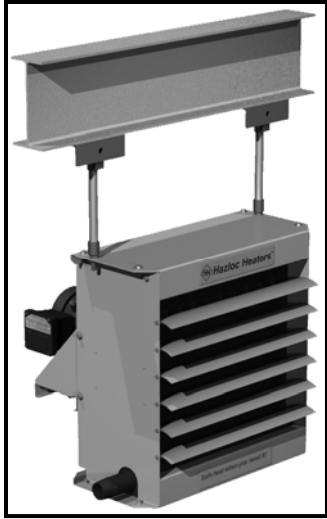

Hanging Mounting Bracket (HMB)

Note: Installer is required to supply:

- A) a method of fastening Top Mount Angle to supporting structure. If using bolts, we recommend four 3/8" diameter, grade 5 bolts.**
- B) two pieces of 1/2", schedule 40 or greater, steel pipe cut to required length and threaded on both ends.**

STEP 1

Fasten Top Mount Angles to structure or surface that will support the heater's weight (see heater owners manual for distance between mounting holes).

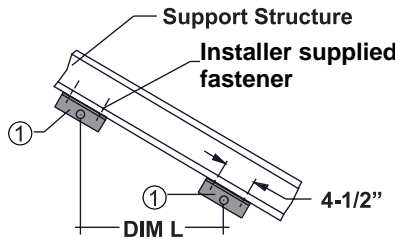

DIM L = Distance between mounting holes. (Refer to owner's manual)

STEP 2

Screw one Pipe Hanger Adapter and one Heater Adapter onto each steel pipe until tight (minimum 5 turns).

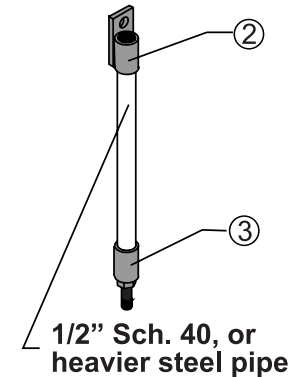

PACKAGE CONTENTS

Item	Qty.	Description
①	2	Top Mount Angle
②	2	Pipe Hanger Adapter
③	2	Heater Adapter
④	2	Bolt, 1/2" - 13UNC x 1-1/4"
⑤	2	Lock Nut, 1/2" - 13UNC
⑥	4	Flange Nut, 1/2" - 13UNC

STEP 3

Insert hanger assemblies from Step 2 into mounting holes on top of heater cabinet and fasten using 1/2" - 13UNC flange nuts.

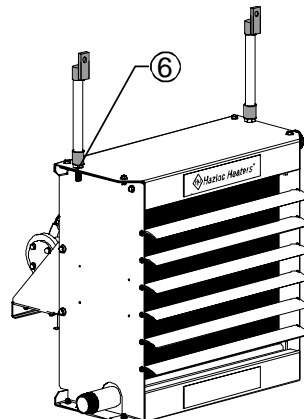

STEP 4

Hang heater from the inside of Top Mount Angle (as shown) using two 1/2" - 13UNC x 1-1/4" bolts and 1/2" - 13UNC lock nuts. Do not back off more than 3/4 turns.

