

**Notes**

**1. Net weight**

Without Thermostat or Disconnect Switch  
25 & 30 kW = 201 lbs (91.5 kg)

**Net Weight Adders**  
Thermostat = 7 lbs (3.1 kg)  
Disconnect Switch = 11 lbs (4.9 kg)

**2. Shipping Weight**

Without Thermostat or Disconnect Switch  
25 & 30 kW = 270 lbs (122.5 kg)

**Ship Weight Adders**  
Thermostat = 7 lbs (3.1 kg)  
Disconnect Switch = 11 lbs (4.9 kg)

**3. Ambient Temperature Limits and Altitude**

Operating: **Gas:** -40°C ≤ Tamb ≤ +40°C  
Storage: -50°C to +60°C  
Maximum Altitude: 3000 m ASL

**4. Air Delivery**

25 kW = 3568 m<sup>3</sup>/hr  
30 kW = 5097 m<sup>3</sup>/hr

**5. Hazardous Location Classification**

Ⓒ 2813 Ⓔ II 2G, Ex db h IIB T4 Gb IP55 (ATEX)  
Ex d IIB T4 Gb IP55 (IECEX)  
Ⓔ II 2G, Ex db h IIB T4 Gb IP55 (UKEX)  
(Suitable for ATEX/IECEX/UKEX Zone 1 & 2)

**6. Materials**

Cabinet: 14 Ga, Yellow Epoxy/Polyester Powder Coated  
Core: Carbon Steel with Copper-free Integral Aluminum Fins Coated with Black, High Heat Enamel  
(Heresite coated core and/or cabinet available)

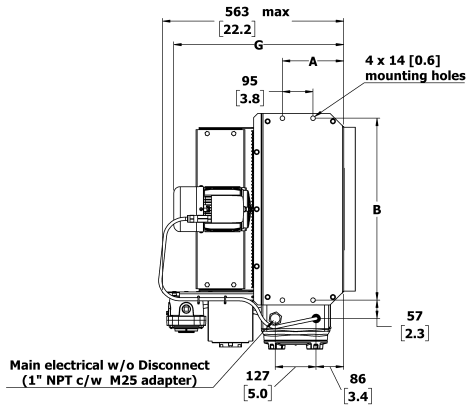

Heater Size	20 (25-30kW)
Dim.	Inches (mm)
A	7.5 (191)
B	26.3 (667)
C	24.3 (617)
D	27.0 (686)
E	27.4 (697)
F	7.1 (181)
G	20.8 (528)
H	16.7 (424)

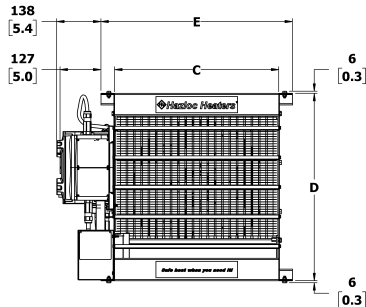
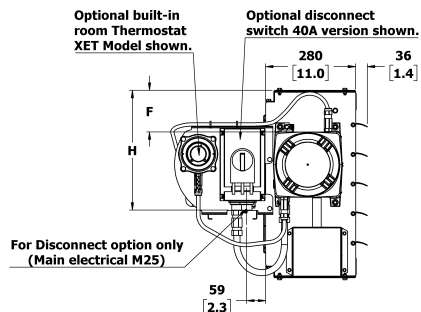

**Table 1 Specifications for AEU1 Heater, 20" Fan Size**

KW	Line Volt	PH	Hz	Fan Dia. (inch)	Total Amps	Minimum Circuit Ampacity	Max Fuse Size	Supply Wire 90°C mm <sup>2</sup> (AWG)	BASE MODEL	Optional Built-in Thermostat [circle one]	Built-in Disconnect Switch <input checked="" type="checkbox"/>	Continuous Fan <input checked="" type="checkbox"/>
25	400	3	50	20	37.1	46.4	50	8.36 (8)	AEU1-G-20-250-400350-B	None or T1 or T2		
	480	3	60		31.1	38.9	40	8.36 (8)	AEU1-G-20-250-480360-B	None or T1 or T2		
30	400	3	50	20	44.3	55.4	60	13.3 (6)	AEU1-G-20-300-400350-B	None or T1 or T2	(not available)	
	480	3	60		37.1	46.4	50	8.36 (8)	AEU1-G-20-300-480360-B	None or T1 or T2		

**Heater Model Code & Option Codes**

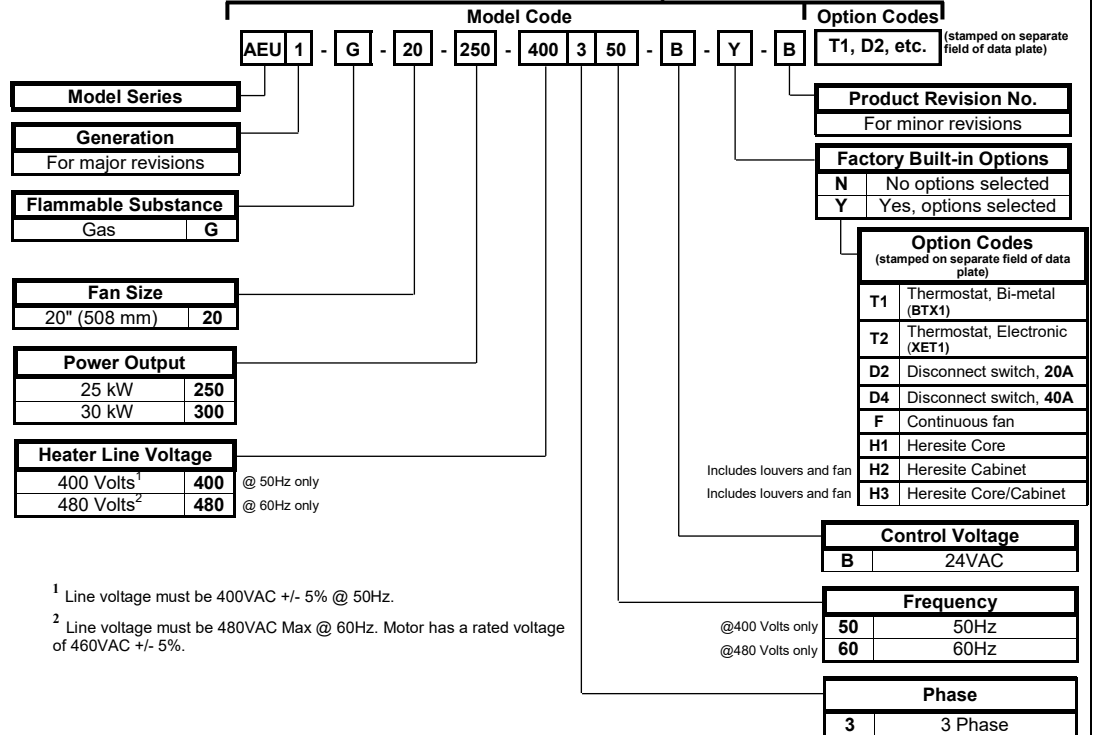

Approval Drawing	AEU1, 20" Fan Size Heater
January 31, 2024	Version 4.0
Hazloc Heaters Inc.	Calgary, Alberta



### Wiring Diagram for Standard Fan Operation

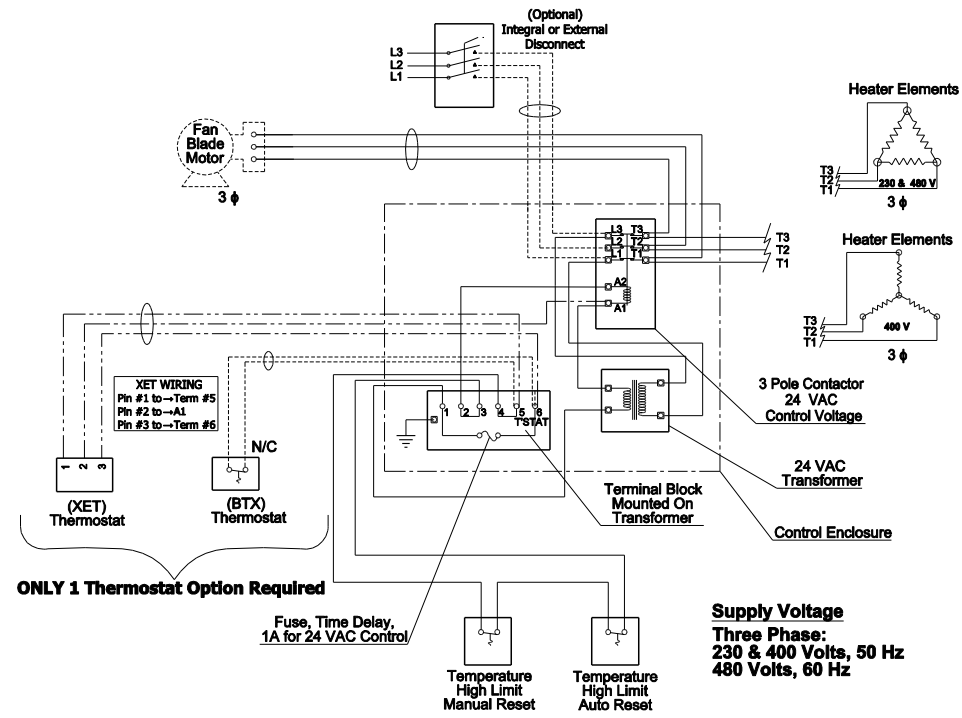

### Wiring Diagram for Continuous Fan Operation

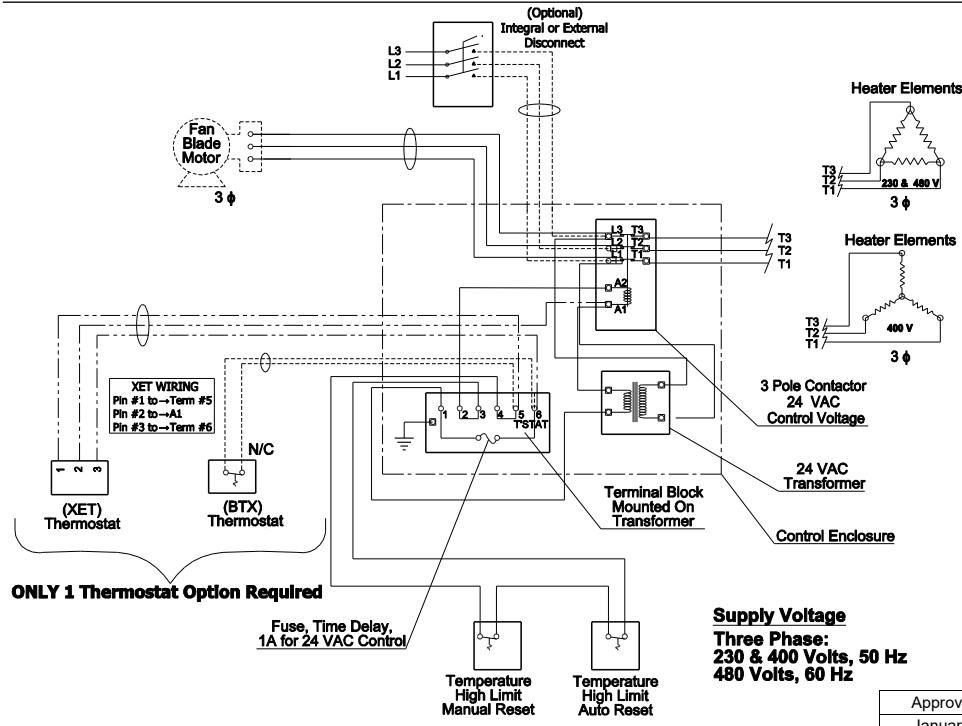

Approval Drawing	AEU1, 20" Fan Size Heater
January 31, 2024	Version 4.0
Hazloc Heaters Inc.	Calgary, Alberta

