



EXcaliber™ BTX1

Bi-Metal Thermostat Installation and Maintenance Manual

Hazardous Location Ratings



Gas Atmospheres (ATEX / IECEx / UKEX)

C E 2813 Ex II 2G Ex db IIB+H₂ T6 Gb (ATEX)
 Ex db IIB+H₂ T6 Gb (IECEx)
 Ex II 2G Ex db IIB+H₂ T6 Gb (UKEX)
 -50°C ≤ T_{amb} ≤ +40°C, IP65
 (Certified for ATEX / IECEx / UKEX Zone 1 and 2)

And

Dust Atmospheres (ATEX / IECEx / UKEX)

C E 2813 Ex II 2D Ex tb IIIC T85°C Db (ATEX)
 Ex tb IIIC T85°C Db (IECEx)
 Ex II 2D Ex tb IIIC T85°C Db (UKEX)
 -50°C ≤ T_{amb} ≤ +40°C, IP65
 (Certified for ATEX / IECEx / UKEX Zone 21 and 22)

Dimensions

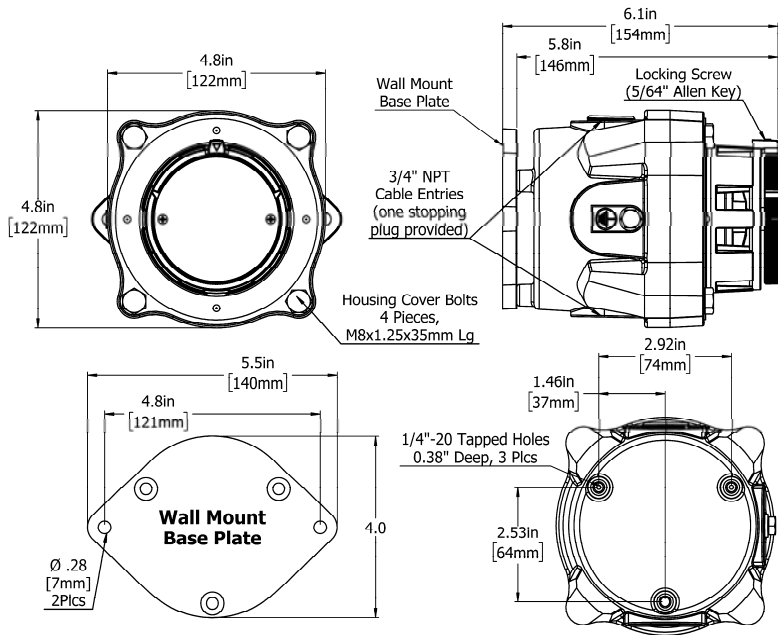

BTX1 Model Coding

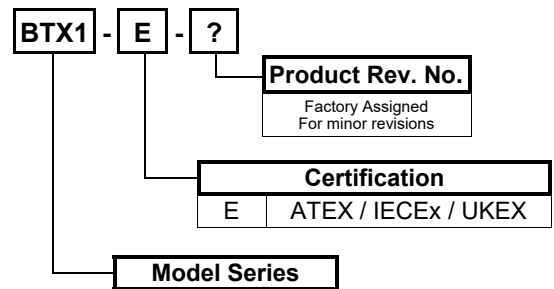

Cable Entries

(2x) 3/4"-14 NPT

Operation

- Temperature set point can be locked via the set screw located behind the pointer.
Use a 5/64" allen key to lock / unlock the set screw.
- Rotate the temperature adjustment knob until the desired set temperature is indicated by the pointer.
- Thermostat is factory calibrated. Thermostat cannot be calibrated in the field.

Specifications

- Temperature adjustment range is 5°C to 25°C (40°F to 80°F).
- Temperature differential (hysteresis) = +/- 1°C (+/- 1.8°F) from set point.
- **Electrical Ratings:** 22 Amp up to 480VAC, 50/60 Hz; 1/2HP @ 125VAC; 1HP @ 250VAC
- PILOT DUTY: 490 VA @ 125VAC, 800 VA @ 250VAC
- Storage temperature: -50°C to +60°C (-58°F to 140°F).
- SPDT for heating or cooling applications.

Conditions For Safe Use

- The thermostat must not be physically modified in any way.
- Thermostats are to be installed with the operating shaft in the horizontal orientation only and is suitable for IP65 applications (see figure 4).
- The thermostat does not have any field replaceable or repairable components. Any component replacement or repair performed in the field may void the hazardous certification ratings.
- When tightly closed the cover flamepath gap must not exceed 0.0015" (0.04mm).
- Stopping plugs and blanking elements shall not be used in conjunction with an adaptor or reducer.
- Where adaptors and reducers without sealing rings are installed in protection by enclosure, Ex t (equipment for use in explosive dust atmospheres), they may only be fitted into enclosures offering a minimum of five full threads engagement in accordance with 60079-31.
- Adaptors or reducers shall not be used for the direct connection of the thermostat to another enclosure.
- Only one adaptor or reducer is to be used with any single cable entry on the associated equipment.
- **CAUTION:** To prevent the risk of ignition of hazardous atmospheres ensure the cover is tightly closed when the circuits are alive. Disconnect the supply before opening the enclosure.

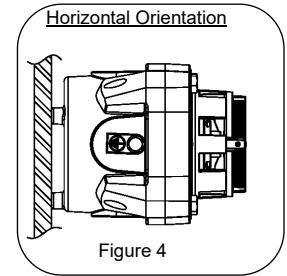

Installation / Wiring

- Thermostat is to be connected and serviced only by a qualified electrician experienced with hazardous location equipment. It is the responsibility of the installer to verify the safety and suitability of the installation as per all electrical codes and area regulations.
- Connection may be made via glands and cable that are appropriately certified for use in the hazardous location and correctly installed. OR
- Connection may be made via rigid conduits.
⇒ For installation in ATEX, IECEx, or UKEX hazloc classified areas the conduits must be sealed at the thermostat end of the enclosure. The seal must be certified for use in the appropriate hazardous location and correctly installed.
- All unused cable entries must be fitted with stopping plugs or blanking elements which are appropriately certified for use in the hazardous location and correctly installed.
- Electrical ratings stated in literature and on nameplates must not be exceeded.
- Both an internal and external earthing points are provided. The external grounding terminal is NOT to be used as the primary equipment ground. The interior grounding terminal is the primary equipment ground.
- Upon completion of the wiring the thermostat cover is to be re-installed. The flanged surfaces on the base housing and cover are to be free of dirt and debris. The four M8 hex bolts are to be torqued to 150 in-lbs (17 Nm).
- Base housing and cover are to be assembled as such that a 0.0015" (0.04mm) feeler gauge can't be inserted between the two flanged faces.
- Any unused wires must be insulated via wire nut or similar method.
- For 22 amp loads the required field wiring is 12 AWG rated at 90C .
- If the thermostat is connected to the control circuit of the AEU1 forced air electric heater then 18 AWG, 90C wire is acceptable .
- For any other amp load to be controlled directly with the BTX refer to the local electrical code.

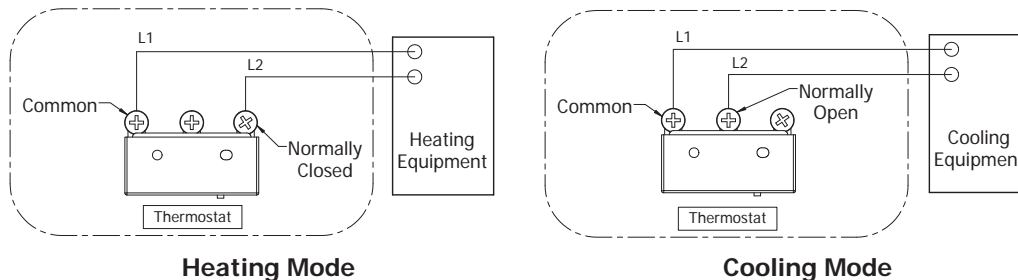

Routine Maintenance

- For optimal operation remove excess dust / debris using compressed air.
- Ensure all field wiring connections are secure and free of excess wear.
- Ensure all stopping plugs, blanking elements, and fittings are tight and secure.

Limited 36-Month Warranty

All BTX1 series of bi-metal explosion-proof thermostats are warranted against defects in materials and workmanship under normal conditions of use for a period of thirty-six (36) months from date of purchase based on the following terms:

- The thermostat must not be modified in any way.
- The thermostat must be stored, installed and used only in accordance with the owner's manual and attached data plate information.
- The complete thermostat may be returned to our manufacturing plant for repair or replacement (at our discretion), freight charges prepaid.
- Contamination by dirt, dust, etc. or corrosion will not be considered as defects.
- This warranty shall be limited to the actual equipment involved and, under no circumstances, shall include or extend to installation or removal costs, or to consequential damages or losses.