



Hazloc Heaters™

Safe heat when you need it!



Includes our

SAFE DEFORM™

Feature!

SRH2

Steam Rig Heater

CRN: 0H14931.2C
200 psig (1379 kPa)

Industrial Grade
Heat-Exchanger Unit Heaters

www.HazlocHeaters.com



Hazloc Heaters™ is a manufacturer of industrial-grade unit heaters, exhaust fans, and accessories suitable for hazardous and severe-duty locations.



The **Steam Rig Heater (SRH2)** series of heat-exchanger unit heaters is specifically designed to meet the demanding requirements of the oil & gas well drilling industry. The harsh operating conditions of this industry require heating equipment that is safe, reliable, dependable, and available when you need it. The **SRH2** series of heaters are built with you in mind, because we know that boiler failure or system neglect could result in an accidental freeze-up of the heating system.

Simple, yet effective... with you in mind!

All **Hazloc Heaters™ SRH2** models are **designed to ASME requirements** for steam applications with **maximum operating pressures up to 200 PSIG (1379 kPa)**. The six sizes of **SRH2** heaters include our **SafeDeform™** top and bottom core headers which are designed to deform to the increased volume, due to ice expansion, during freeze-up conditions. This feature allows **SRH2** heaters to be frozen several times without critical damage which keeps your safety in mind. With our **SafeDeform™** feature, multi-pass core configurations are not available.



Rugged design, but easily maintained and reversible!

All **SRH2** heaters are designed for industrial applications with all features being heavy-duty to meet your most demanding environments and long-life expectations. Even with heavy-gauge steel construction used throughout the heater it does not inhibit the easy maintenance of the product, since all parts are easily removed. Furthermore, the heater core can be removed without disturbing the heater mounting arrangement or electrical connections. An additional benefit is our reversible core connection feature that allows you to reverse the configuration of the inlet and outlet connection locations, by rotating the core, to suit your installation! (see photo on bottom of page 3)

Interchangeable with other brands of heaters!

Some of **Hazloc Heaters™ SRH2** series are designed with cabinet dimensions and mounting holes equivalent to a major competitor's heaters making them easily interchangeable. Furthermore, our rugged and superior **SRH2 SafeDeform™** replacement cores are also designed to slide into equivalent sizes of their heaters. Added benefits include our 18-month heater warranty.

Maximum durability... rugged fin tubes and headers!

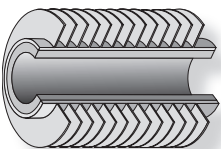

All **SRH2 SafeDeform™** heat-exchanger cores are constructed using rugged 16-gauge (0.065 in.) carbon-steel tubes with tension-wound aluminum fins and 3/16 in. (4.8 mm) carbon-steel headers for **maximum durability, resistance to corrosion, and longer life** in your demanding applications.



Dedicated to Performance and Reliability!

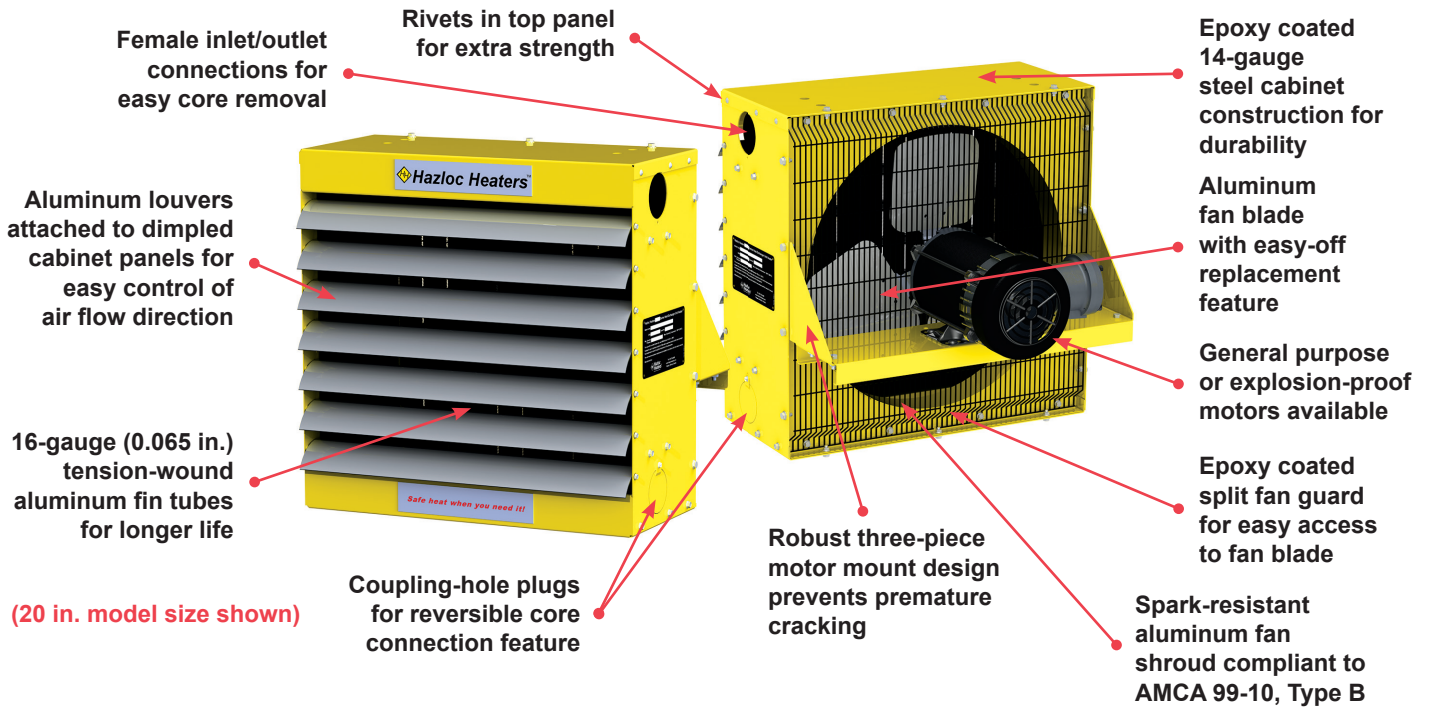

SRH2 Physical Dimensions (12 inch to 30 inch models)

Note: Inlet and outlet coupling connection locations can be reversed in the field by rotating the core.

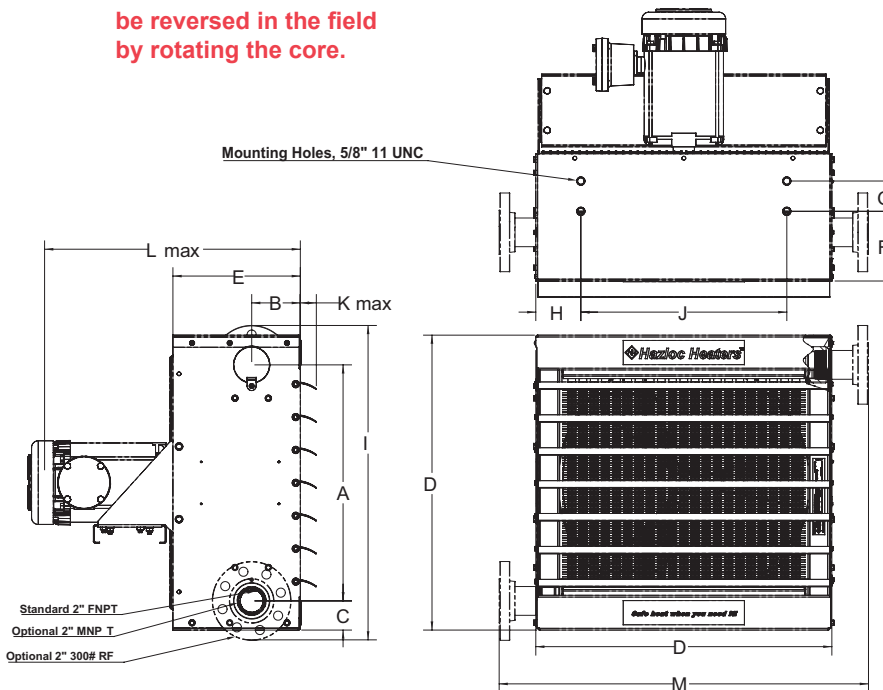

Fan Size	12	16	20	24	30
Dim.	Inches (mm)	Inches (mm)	Inches (mm)	Inches (mm)	Inches (mm)
A	12.60 (320)	15.51 (394)	19.49 (495)	23.46 (596)	29.53 (750)
B	4.02 (102)	4.02 (102)	4.02 (102)	4.65 (118)	5.71 (145)
C	1.85 (47)	2.38 (60.5)	2.40 (61)	2.40 (61)	2.40 (61)
D	16.30 (414)	20.28 (515)	24.29 (617)	28.27 (718)	34.33 (872)
E	9.76 (248)	9.76 (248)	10.51 (267)	11.81 (300)	13.78 (350)
F	6.77 (172)	5.77 (146.5)	5.75 (146)	6.69 (170)	7.48 (190)
G	(2 holes)	1.75 (44.5)	2.50 (63.5)	2.76 (70)	3.15 (80)
H	2.64 (67)	2.64 (67)	3.62 (92)	4.29 (109)	4.37 (111)
I	19.07 (484)	21.98 (558)	25.96 (659)	29.93 (760)	36.00 (914)
J	11.02 (280)	15.00 (381)	17.00 (432)	19.69 (500)	25.59 (650)
K	1.38 (35)	1.38 (35)	1.38 (35)	1.38 (35)	1.38 (35)
L	19.86 (504)	19.86 (504)	22.57 (573)	23.90 (607)	26.37 (670)
M	22.49 (571)	26.47 (672)	30.48 (774)	34.46 (875)	40.5 (1029)

Dedicated to Performance and Reliability!

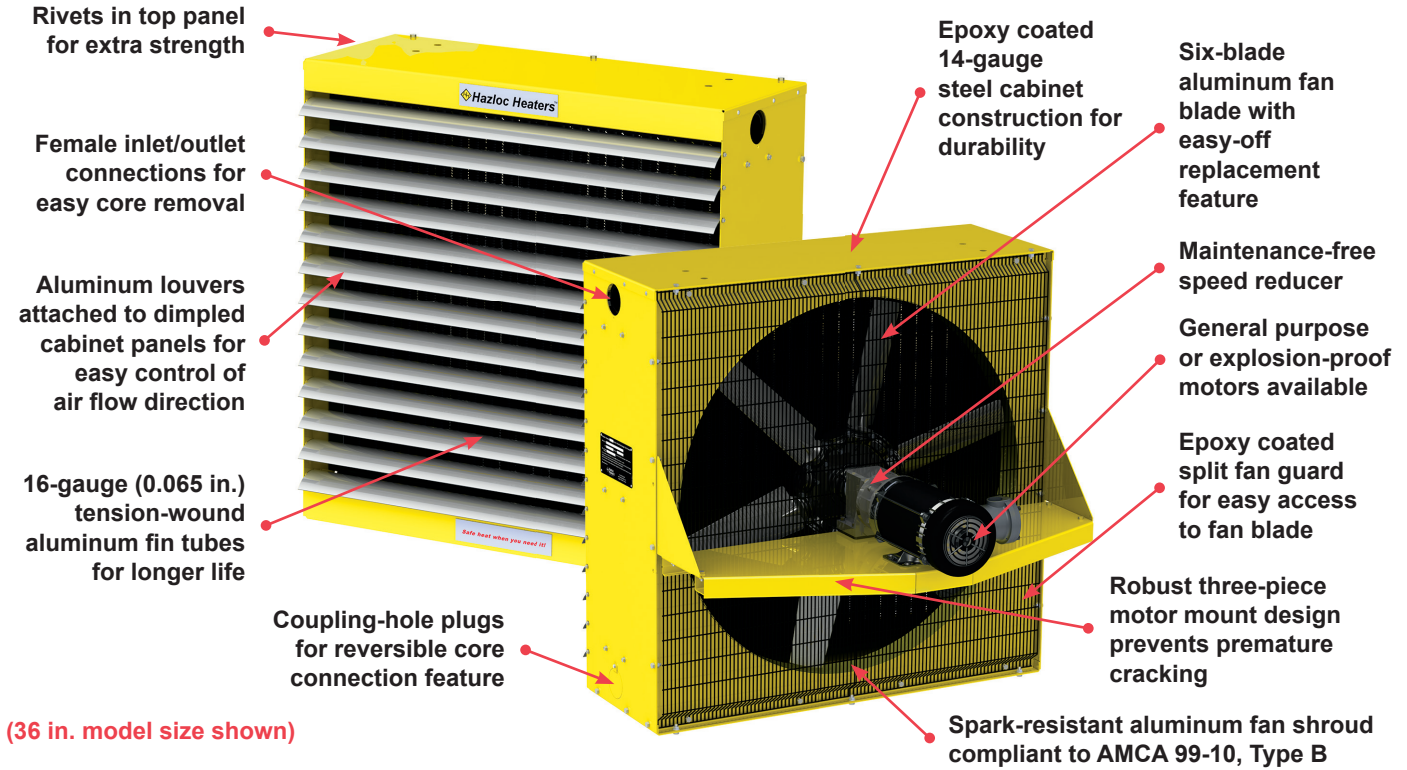

SRH2 Physical Dimensions (36 inch model)

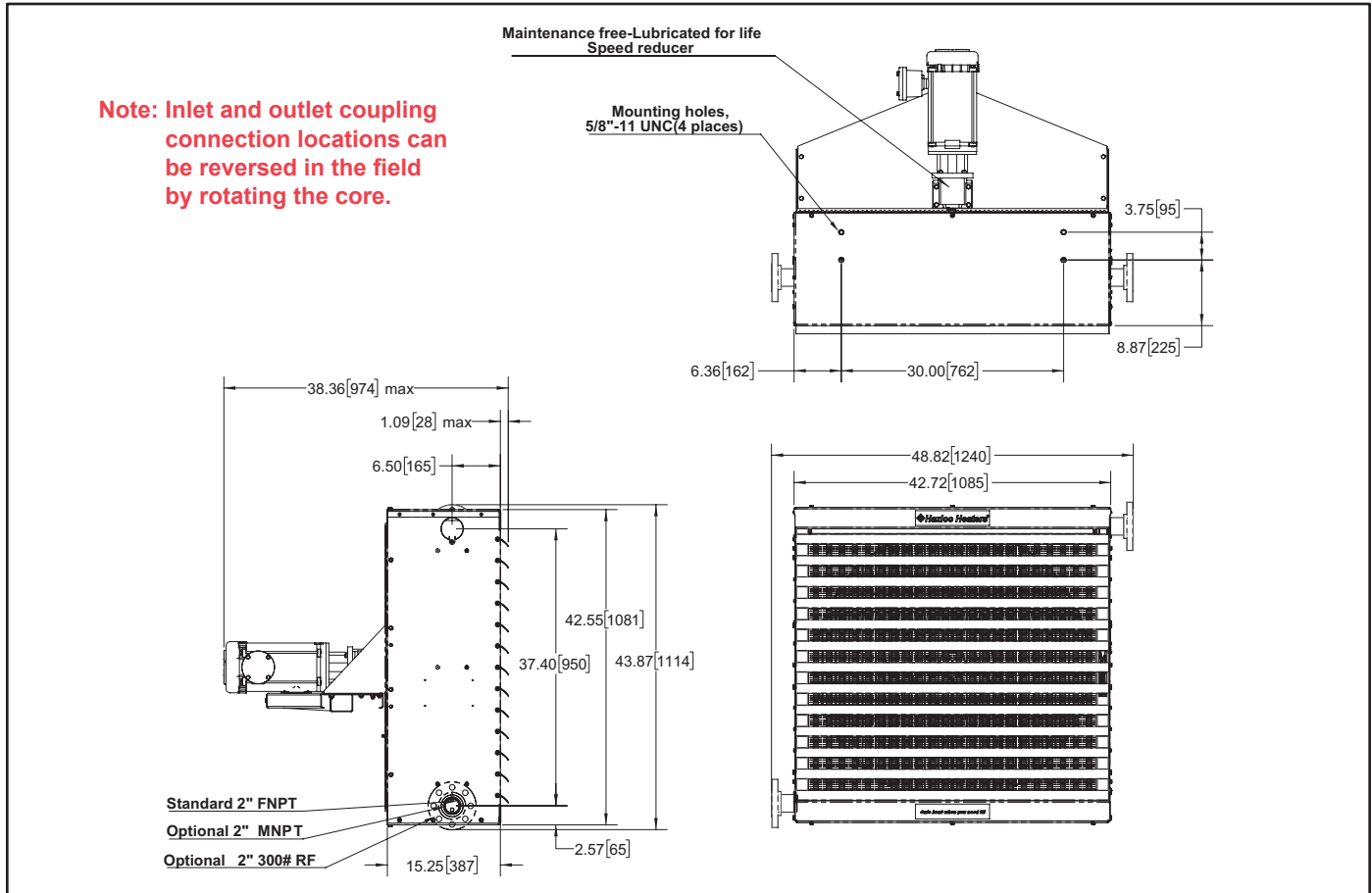

SRH2 Model Coding



Heater Model Code & Option Codes

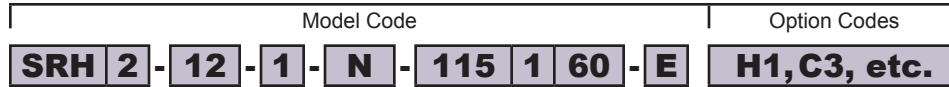

Model Series
SRH

Generation
For major revisions

Fan Size	
12 inches	12
16 inches	16
20 inches	20
24 inches	24
30 inches	30
36 inches	36

Tube Passes	
1 Pass	1

Approval Type	
North American (GRN)	N

Includes louvers and fan blade
Includes louvers and fan blade

Options	
H1 ^Δ	Heresite coated core
H2 ^Δ	Heresite coated cabinet
H3 ^Δ	Heresite coated core & cabinet
C2 [◇]	Connection, 2" MNPT SCH. 80 fitting
C3 [◇]	Connection, 2" FNPT CL300# RF flange
ZZ	Special build (Factory assigned code)

Motor Type	
G	General purpose
E [†]	Hazardous location

Motor [‡]		
Voltage	Phase	Frequency
115	1	60
208	1	60
230	1	60
208	3	60
230	3	60
460	3	60
575	3	60

- Δ Contact factory for extended shipping lead times on Heresite coatings.
- ◇ Thread-on fittings. Shipped loose and must be installed on site. C3 connection also includes C2 connection.
- † Standard Marathon NEMA ex-proof motor is suitable for Class I & II, Div. 1 & 2, Groups C, D, F & G; T3B; Maximum ambient air temp of 40°C.
- * Other voltages / frequencies available upon request. Longer lead times may apply. Contact factory.
- ‡ NEMA motors are to be operated at ±10% of the nameplate voltage. Some motor manufacturers state that the motor is "usable at 208V" in their product literature but the line voltage must still meet the ±10% nameplate voltage tolerance (e.g. the permissible voltage range for a 230V motor is 207V - 253V).
For 3-phase motors the line-to-line full load voltage must be balanced within 1%.

Nomenclature/Formulas/Conversions

10³ – 1000

BTU – British Thermal Unit

Cond. – Condensate Flow Rate

EAT – Entering Air Temperature

ΔT – Fluid Temperature Drop

FAT – Final Air Temperature

PSIG – Pounds Per Square Inch Gauge Pressure

CFM – Cubic Feet Per Minute

USGPM – U.S. Gallons Per Minute

ΔP – Fluid Pressure Drop

$$\text{Condensate (lbs/hr)} = \frac{\text{actual btu/hr}}{\text{Latent Heat of Steam @ PSIG}}$$

1 U.S. Gallon of water = 8.34 lbs of water

1 U.S. Gallon = .8327 Imperial Gallons

1 kW = 3,414 btu/hr

1 Boiler HP = 33,478.8 btu/hr @ 70 psi

Properties of Steam			
Gauge Pressure (PSIG)	Temp. (°F)	Latent Heat (btu/lb)	Density (lb/ft ³)
2	219	965	.0434
10	239	952	.0612
20	259	939	.0855
40	287	919	.1351
50	298	912	.1498
60	307	904	.1818
80	324	891	.2127
100	338	880	.2564
150	366	857	.3634
200	387	838	.4686
300	422	805	.6803
450	460	764	1.0

SRH2 Specifications by Model Size

Model		SRH2-12	SRH2-16	SRH2-20	SRH2-24	SRH2-30	SRH2-36
Fan diameter	in. (mm)	12 (304.8)	16 (406.4)	20 (508.0)	24 (609.6)	30 (762.0)	36 (914.4)
Air delivery*	cfm (m ³ /hr)	1090 (1852)	1650 (2803)	3000 (5097)	3800 (6456)	5500 (9344)	8350 (14,186)
Approx. air velocity*	fpm (m/s)	1305 (6.6)	1111 (5.6)	1309 (6.6)	1138 (5.8)	1066 (5.4)	928 (4.7)
Air throw* @ 15 psi steam	ft (m)	45 (13.7)	65 (19.8)	70 (21.3)	80 (24.4)	85 (25.9)	70 (21.3)
Motor power	hp (watts)	¼ (186) or ⅓ (248)		½ (373)	½ (373)	¾ (559)	1 (746)
Rec. min. mounting height	ft (m)	7.5 (2.3)	7.5 (2.3)	7.5 (2.3)	7.5 (2.3)	7.5 (2.3)	7.5 (2.3)
Net weight (no options)	lbs (kg)	94 (42.6)	114 (51.7)	158 (71.1)	225 (102.1)	279 (126.5)	522 (236.8)
Shipping weight (no options)	lbs (kg)	144 (65.3)	166 (75.3)	216 (98.0)	290 (131.5)	354 (160.6)	634 (287.6)
with 2" NPT nipples (add)		1 (0.4)	1 (0.4)	1 (0.4)	1 (0.4)	1 (0.4)	1 (0.4)
with flanges & nipples (add)		14 (6.3)	14 (6.3)	14 (6.3)	14 (6.3)	14 (6.3)	14 (6.3)

* At 70°F (21°C), 60 Hz and sea level.

SRH2 General Specifications

Approval	CRN: 0H14931.2C - steam or fluids (not for use with lethal fluids as defined by ASME, Section VIII, Div. 1, UW-2).
Maximum pressure rating	200 psig (1379 kPa).
Maximum temperature rating	550 °F (288°C).
Minimum design metal temperature	-20° F (-29° C).
Cabinet material	14-gauge (0.075 in.) (1.9 mm) steel. SRH2-36 is 12-gauge (0.105 in. (2.7 mm) steel on top and bottom panels and motor mount. Yellow epoxy/polyester powder coated with five-stage pretreatment, including iron phosphate. Optional Heresite phenolic coating available. Option Codes H2 or H3 (includes Heresite coating of louvers & fan blade).
Louver blades	Anodized extruded aluminum.
Fan	Spark-resistant three-blade aluminum (except SRH2-30 which is two-blade and SRH2-36 which is six-blade).
Fan shroud	Spark-resistant aluminum. Compliant to AMCA 99-10, Type B.
Fan guard	Split design with close wire spacing. A 3/8 in. (9.5 mm) diameter probe will not enter.
Motor drive	Thermally protected CSA or UL Listed 1725 RPM permanently lubricated ball bearing type with 56 frame and "easy-off" fan blade replacement feature. SRH2-36 is a 56C frame motor and a maintenance-free speed reducer.
Mounting holes	5/8 in. – 11 UNC – 4 holes at top of heater (2 holes, SRH2-12).
Fluid connections	2 in. NPT female inlet and outlet (configuration of fluid connection locations can be reversed by rotating the core). Other thread-on connection types are available. They are shipped loose and must be installed on site. See Option Codes C2 or C3. (C3 connection also includes C2 connection).
Header material	3/16 in. (4.8 mm) carbon steel conforming to ASME requirements.
Finned tubes	5/8 in. (15.9 mm) outside diameter [16-gauge, 0.065 in. (1.6 mm) wall thickness] carbon steel tubes with 1-1/2 in. (38.1 mm) outside diameter copper-free, L-foot, tension-wound aluminum fins @ 10 fins per in.
Exchanger coatings	Standard coating is a black, high-heat enamel paint. Optional Heresite phenolic coating available. Option Codes H1 or H3.

Accessories

Mounting Brackets



WMB*
Wall Mounting Bracket
 For use in buildings that have substantial walls. The Z sections provide additional support where necessary.



BMB*
Basic Mounting Bracket
 For applications where the support arm can be bolted or welded directly to structural steel or concrete.

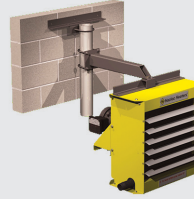

PMB*
Pipe Mounting Bracket
 For buildings with insufficient strength to use other types of mounting brackets. Requires 3 in. pipe (3.5 in. O.D., min. Sch. 40, not supplied).



HMB
Hanging Mounting Bracket
 Ideal and economical if adequate overhead structure exists. Requires 1/2 in. pipe, cut and threaded (min. Sch. 40 not supplied).

Note: When ordering mounting brackets, please specify the type of bracket preferred, the basic model code and fan size of the heater to be mounted. Example, **PMB-SRH2-16**. Mounting kits are made of steel with a black enamel paint finish. Structural support of heater and bracket during transit is required.

* Not suitable for model SRH2-30 or SRH2-36.

Thermostat, Remote Mount

ET9STS (SPST)

Line-Voltage Thermostat
 22 Amps Resistive Load, 277 VAC Max
 3/4 HP@125 VAC; 1-1/2 HP@ 250/277 VAC
 Ship wt - 0.6 lbs (0.28 kg)



BTX2-15A-W-N-A (Bi-metal, SPDT) Heating or Cooling

Class I, Division 1 & 2, Groups B, C & D
 Class II, Division 1, Groups E, F & G
 Class II, Division 2, Groups F & G; Class III; T6
 Class I, Zone 1, Ex db, Groups IIA, IIB+H₂, T6, Gb
 Class I, Zone 2, Ex dc, Groups IIA, IIB+H₂, T6, Gc
 Class I, Zone 1, AEx db, Groups IIA, IIB+H₂, T6, Gb
 Class I, Zone 2, AEx dc, Groups IIA, IIB+H₂, T6, Gc
 Class II, Zone 21, Ex tb, Groups IIIA, IIIB & IIIC, T85°C, Db
 Class II, Zone 22, Ex tc, Groups IIIA, IIIB & IIIC, T85°C, Dc
 Class II, Zone 21, AEx tb, Groups IIIA, IIIB & IIIC, T85°C, Db
 Class II, Zone 22, AEx tc, Groups IIIA, IIIB & IIIC, T85°C, Dc
 -50°C ≤ T amb ≤ +40°C, IP66, Type 4
 Temperature adjustment range: 40°F to 80°F (5°C to 25°C); 3/4" - NPT conduit opening on top and bottom

Ship wt - 3.5 lbs (1.6 kg)

15 Amps Resistive Load, 480VAC Max; 3/4HP @ 125VAC; 1-1/2HP @ 250VAC (suitable for 24VAC or 120VAC control circuit)



Disconnect Switch, Remote Mount

XDC-01

Explosion-proof Disconnect switch
 Class I, Div. 1 & 2, Grp C & D; Class II, Div. 1, Grp E, F & G; Class II, Div. 2, Grp F & G;
 Class III; Class I, Zones 1 & 2, Grp IIA & IIB, T5
 CSA_{C/US} - Certified to Canadian and U.S. standards
 600VAC, 50A max; 15HP @ 208/240VAC, 3 phase; 30HP @ 480/600VAC, 3 phase;
 2HP @ 120VAC, 1 phase; 7.5HP @ 240VAC, 1 phase
 Ship wt - 12.0 lbs (5.4 kg)



How to Order

When asking for a quote or placing an order, please follow the **“Model Coding”** format on page 5 to specify your exact model code configuration. If ordering explosion-proof motors also specify hazardous location area rating required.

Example Model Code: SRH2-16-1-N-115160-E, H3, C2, etc
Suitable for Class I, Div. 1, Group D,
T3B atmosphere

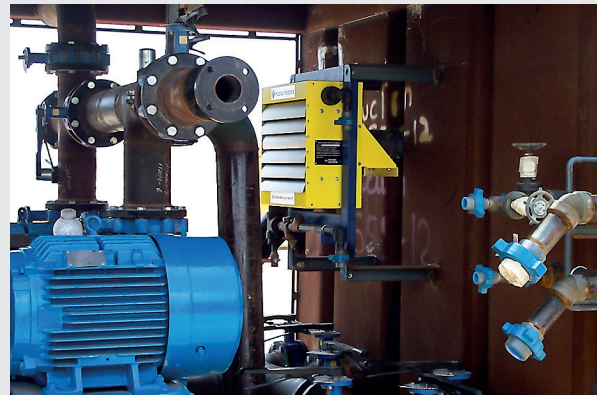

Steam Performance Tables

SRH2-12-1-N-# @60 Hz

PSIG	°F	Performance	Entering Air Temperature								
			-10	0	10	20	30	40	50	60	70
10	239	Output (10 ³ btu/hr)	77	74	70	66	63	59	56	53	49
		Cond. (lbs/hr)	81	77	73	69	66	62	59	55	52
		FAT (°F)	45.6	54.2	62.6	71.0	79.3	87.5	95.7	103.9	111.9
20	259	Output (10 ³ btu/hr)	84	80	76	72	69	65	62	58	55
		Cond. (lbs/hr)	89	85	81	77	73	69	66	62	59
		FAT (°F)	50.2	58.8	67.3	75.8	84.1	92.2	100.4	108.6	116.8
50	298	Output (10 ³ btu/hr)	95	92	88	84	81	77	73	70	66
		Cond. (lbs/hr)	104	100	96	92	88	84	80	77	73
		FAT (°F)	58.8	67.5	76.2	84.7	93.2	101.6	109.9	118.2	126.4
80	324	Output (10 ³ btu/hr)	104	100	96	92	89	85	82	78	75
		Cond. (lbs/hr)	116	112	108	103	99	95	91	87	83
		FAT (°F)	64.9	73.7	82.5	91.1	99.7	108.2	116.6	125.0	133.2
100	338	Output (10 ³ btu/hr)	108	105	101	97	93	89	86	82	79
		Cond. (lbs/hr)	123	118	114	110	105	101	97	93	89
		FAT (°F)	68.1	76.9	85.7	94.4	103.0	111.6	120.0	128.4	136.7
150	366	Output (10 ³ btu/hr)	117	113	109	105	101	98	94	90	87
		Cond. (lbs/hr)	136	131	127	122	118	114	109	105	101
		FAT (°F)	74.3	83.2	92.1	100.9	109.6	118.2	126.8	135.3	143.7

- If using 50 Hz power supply, derate output values by 6%. Above figures are based on calculations at sea level.
- # Refer to page 5 to complete model code for ordering.

SRH2-16-1-N-# @60 Hz

PSIG	°F	Performance	Entering Air Temperature								
			-10	0	10	20	30	40	50	60	70
10	239	Output (10 ³ btu/hr)	123	117	111	105	100	94	89	84	78
		Cond. (lbs/hr)	129	122	116	110	104	99	93	88	82
		FAT (°F)	48.5	56.9	65.3	73.5	81.7	89.8	98.0	106.0	113.9
20	259	Output (10 ³ btu/hr)	132	126	121	115	109	104	98	93	87
		Cond. (lbs/hr)	141	134	128	122	116	110	104	99	93
		FAT (°F)	53.1	61.6	70.0	78.3	86.6	94.8	103.0	111.0	119.0
50	298	Output (10 ³ btu/hr)	152	146	140	134	128	122	117	111	106
		Cond. (lbs/hr)	166	160	153	146	140	134	128	122	116
		FAT (°F)	62.4	71.0	79.5	88.0	96.4	104.7	112.9	121.1	129.2
80	324	Output (10 ³ btu/hr)	166	159.0	153	147.0	141	135	130	124	118
		Cond. (lbs/hr)	185	178.0	171	165.0	158	151	145	139	132
		FAT (°F)	68.9	77.6	86.2	94.8	103.2	111.6	119.9	128.2	136.3
100	338	Output (10 ³ btu/hr)	173	166	160	154	148	142	136	130	125
		Cond. (lbs/hr)	195	188	181	174	168	161	154	148	141
		FAT (°F)	72.2	81.0	89.6	98.2	106.7	115.1	123.5	131.8	140.0
150	366	Output (10 ³ btu/hr)	186	180	174	168	161	155	150	144	138
		Cond. (lbs/hr)	217	209	202	195	188	181	174	167	160
		FAT (°F)	78.8	87.6	96.4	105.1	113.7	122.2	130.6	139.0	147.3

- If using 50 Hz power supply, derate output values by 6%. Above figures are based on calculations at sea level.
- # Refer to page 5 to complete model code for ordering.

Steam Performance Tables

SRH2-20-1-N-# @60 Hz

PSIG	°F	Performance	Entering Air Temperature								
			-10	0	10	20	30	40	50	60	70
10	239	Output (10 ³ btu/hr)	207	197	187	178	168	159	150	141	132
		Cond. (lbs/hr)	217	207	196	186	177	167	157	148	139
		FAT (°F)	44.3	52.9	61.2	69.7	78.1	86.4	94.6	102.8	110.9
20	259	Output (10 ³ btu/hr)	227	217	207	197	187	178	168	159	150
		Cond. (lbs/hr)	241	230	220	209	199	189	179	169	159
		FAT (°F)	49.4	58.0	66.5	75.0	83.4	91.7	100	108.1	116.2
50	298	Output (10 ³ btu/hr)	260	250	239	229	220	210	200	191	181
		Cond. (lbs/hr)	285	274	262	251	240	230	219	209	198
		FAT (°F)	58.2	66.9	75.5	84.1	92.6	101	109.3	117.7	125.9
80	324	Output (10 ³ btu/hr)	284	273	262	252	242	232	222	212	203
		Cond. (lbs/hr)	317	305	294	282	271	260	249	238	227
		FAT (°F)	64.3	73.1	81.8	90.4	99.0	107.5	115.9	124.3	132.6
100	338	Output (10 ³ btu/hr)	296	285	274	264	254	243	234	224	214
		Cond. (lbs/hr)	335	323	311	299	287	276	265	254	243
		FAT (°F)	67.4	76.3	85.0	93.7	102.3	110.8	119.3	127.7	136.0
150	366	Output (10 ³ btu/hr)	319	308	297	287	276	266	256	246	237
		Cond. (lbs/hr)	371	359	346	334	322	310	298	287	275
		FAT (°F)	73.6	82.5	91.4	100.2	108.9	117.5	126.0	134.5	142.9

- If using 50 Hz power supply, derate output values by 6%. Above figures are based on calculations at sea level.
- # Refer to page 5 to complete model code for ordering.

SRH2-24-1-N-# @60 Hz

PSIG	°F	Performance	Entering Air Temperature								
			-10	0	10	20	30	40	50	60	70
10	239	Output (10 ³ btu/hr)	426	403	383	362	342	323	304	286	267
		Cond. (lbs/hr)	446	422	401	379	359	338	319	299	280
		FAT (°F)	77.9	85.1	92.5	99.8	107	114.2	121.2	128.1	135
20	259	Output (10 ³ btu/hr)	471	448	427	406	385	364	344	325	305
		Cond. (lbs/hr)	500	476	453	431	409	387	366	345	325
		FAT (°F)	87.2	94.7	102.1	109.4	116.6	123.7	130.6	137.5	144.3
50	298	Output (10 ³ btu/hr)	540	518	495	474	452	431	410	390	370
		Cond. (lbs/hr)	591	566	542	518	495	472	449	427	405
		FAT (°F)	101.7	109.4	116.9	124.4	131.7	138.9	146.1	153.1	160.1
80	324	Output (10 ³ btu/hr)	589	566	543	521	499	477	456	436	415
		Cond. (lbs/hr)	659	633	608	583	558	534	510	487	465
		FAT (°F)	111.9	119.7	127.3	134.9	142.3	149.6	156.9	164.0	171.0
100	338	Output (10 ³ btu/hr)	614	591	568	545	523	501	480	459	439
		Cond. (lbs/hr)	696	669	643	618	593	568	544	520	497
		FAT (°F)	117.1	124.9	132.7	140.3	147.8	155.1	162.4	169.6	176.7
150	366	Output (10 ³ btu/hr)	665	641	618	594	572	550	528	506	486
		Cond. (lbs/hr)	773	745	718	691	665	639	614	589	565
		FAT (°F)	127.4	135.4	143.2	151.0	158.5	166.1	173.5	180.8	188

- If using 50 Hz power supply, derate output values by 6%. Above figures are based on calculations at sea level.
- # Refer to page 5 to complete model code for ordering.

Steam Performance Tables

SRH2-30-1-N-# @60 Hz

PSIG	°F	Performance	Entering Air Temperature								
			-10	0	10	20	30	40	50	60	70
10	239	Output (10 ³ btu/hr)	658	625	593	561	530	499	470	441	412
		Cond. (lbs/hr)	690	655	621	588	555	523	492	462	432
		FAT (°F)	84	91.2	98.4	105.4	112.4	119.2	126.1	132.7	139.3
20	259	Output (10 ³ btu/hr)	711	678.0	644.0	612	580	549	520	490	461
		Cond. (lbs/hr)	755	719.0	684.0	650	617	584	552	520	490
		FAT (°F)	91.6	98.9	106.1	113.2	120.3	127.1	134.1	140.8	147.5
50	298	Output (10 ³ btu/hr)	818	783	749	715	683	650	619	589	559
		Cond. (lbs/hr)	894	856	819	782	747	712	677	644	611
		FAT (°F)	106.7	114.2	121.6	128.9	136.1	143.2	150.2	157.1	163.9
80	324	Output (10 ³ btu/hr)	892	857	821	787	754	721	688	657	627
		Cond. (lbs/hr)	998	958	919	880	843	806	770	735	701
		FAT (°F)	117.4	125.0	132.5	139.9	147.1	154.3	161.4	168.4	175.3
100	338	Output (10 ³ btu/hr)	930	894	859	824	790	757	725	693	661
		Cond. (lbs/hr)	1054	1013	973	933	895	857	821	785	749
		FAT (°F)	122.9	130.6	138.1	145.5	152.9	160.1	167.2	174.2	181.2
150	366	Output (10 ³ btu/hr)	1007	970	934	899	864	830	797	765	732
		Cond. (lbs/hr)	1171	1128	1086	1045	1005	966	927	889	852
		FAT (°F)	133.7	141.5	149.2	156.8	164.3	171.6	178.8	185.9	193

- If using 50 Hz power supply, derate output values by 6%. Above figures are based on calculations at sea level.
- # Refer to page 5 to complete model code for ordering.

SRH2-36-1-N-# @60 Hz

PSIG	°F	Performance	Entering Air Temperature								
			-10	0	10	20	30	40	50	60	70
10	239	Output (10 ³ btu/hr)	1048	995	943	892	842	793	744	695	649
		Cond. (lbs/hr)	1101	1045	990	937	885	833	778	730	682
		FAT (°F)	88.6	95.7	102.6	109.5	116.2	122.9	129.3	135.5	141.8
20	259	Output (10 ³ btu/hr)	1132	1078	1025	973	922.0	873	819.0	772	725
		Cond. (lbs/hr)	1206	1148	1091	1036	982.0	929	873.0	822	772
		FAT (°F)	96.5	103.6	110.7	117.6	124.4	131.2	137.3	143.8	150.3
50	298	Output (10 ³ btu/hr)	1300	1244	1189	1136	1083	1032	981	933	883
		Cond. (lbs/hr)	1427	1365	1305	1246	1188	1132	1077	1023	970
		FAT (°F)	112.3	119.6	126.8	133.9	140.9	147.8	154.6	161.3	167.8
80	324	Output (10 ³ btu/hr)	1414	1357	1300	1246	1192	1140	1088	1038	983
		Cond. (lbs/hr)	1586	1522	1459	1397	1337	1278	1221	1165	1102
		FAT (°F)	123.0	130.4	137.8	144.9	152.0	159.0	165.9	172.7	178.8
100	338	Output (10 ³ btu/hr)	1474	1416	1358	1302	1249	1196	1144	1093	1044
		Cond. (lbs/hr)	1673	1607	1542	1479	1417	1357	1299	1241	1185
		FAT (°F)	128.6	136.1	143.4	150.6	157.8	164.9	171.9	178.7	185.5
150	366	Output (10 ³ btu/hr)	1591	1532	1474	1418	1362	1308	1255	1203	1153
		Cond. (lbs/hr)	1851	1782	1715	1649	1584	1521	1460	1399	1341
		FAT (°F)	139.6	147.3	154.8	162.2	169.4	176.6	183.6	190.6	197.5

- If using 50 Hz power supply, derate output values by 6%. Above figures are based on calculations at sea level.
- # Refer to page 5 to complete model code for ordering.

Additional Products Available

Hazloc Heaters™ offers a wide variety of steam/hydronic air heaters, explosion-proof electric air heaters, washdown/corrosion resistant air heaters, non-hazardous area air heaters, air sensing thermostats, disconnect switches and other related accessories.

Please visit www.HazlocHeaters.com and click on the *Products* link.



 **Hazloc Heaters™** *“Safe heat when you need it!”*

Quality Mission Statement

Quality is... customers that come back, and products that don't.

Limited 18-Month Warranty

Hazloc Heaters™ warrants all **SRH2** series of heat-exchanger unit heaters against defects in materials and workmanship under normal conditions of use for a period of eighteen (18) months from date of purchase based on the following terms:

1. The heater must not be modified in any way.
2. The heater must be stored, installed and used only in accordance with the owner's manual and attached data plate information.
3. Replacement parts will be provided free of charge as necessary to restore any unit to normal operating condition, provided that the defective parts be returned to us freight prepaid and that the replacement parts be accepted freight collect.
4. The complete heater may be returned to our manufacturing plant for repair or replacement (at our discretion), freight charges prepaid.
5. Contamination by dirt, dust, etc. or corrosion will not be considered as defects.
6. This warranty shall be limited to the actual equipment involved and, under no circumstances, shall include or extend to installation or removal costs, or to consequential damages or losses.



**Hazloc
Heaters™**

Safe heat when you need it!

#1, 666 Goddard Ave. NE
Calgary, Alberta T2K 5X3 Canada
Tel.: +1-403-730-2488
Fax: +1-403-730-2482
Customer Toll Free (U.S. & Canada):
+1-866-701-Heat (4328)
www.HazlocHeaters.com



Available from: